

S-I SERIES

SIP/CIP
CUSTOMIZABLE PILOT
AND INDUSTRIAL
SCALE FERMENTERS
BIOREACTORS

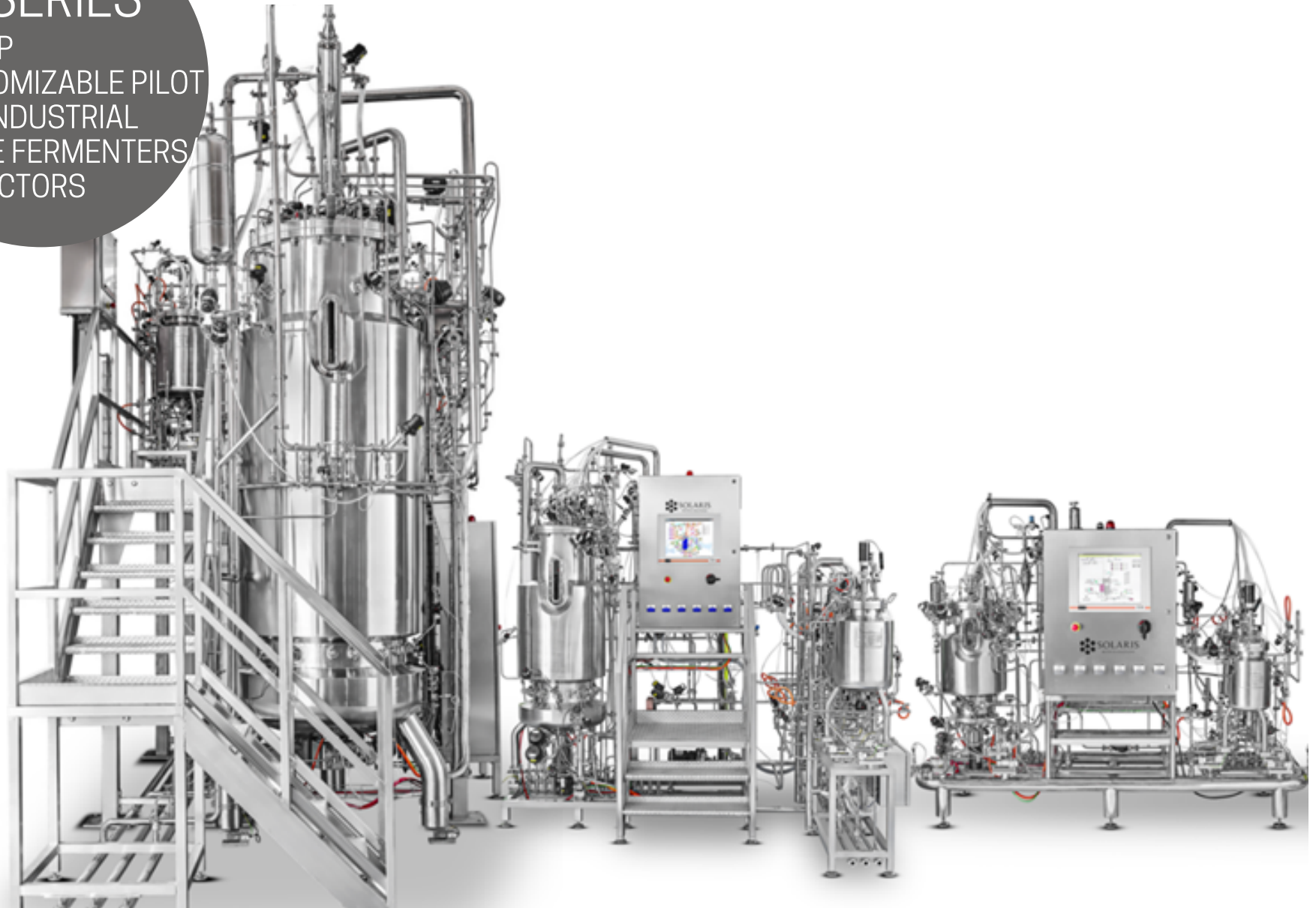

SOLARIS
BIOTECH SOLUTIONS

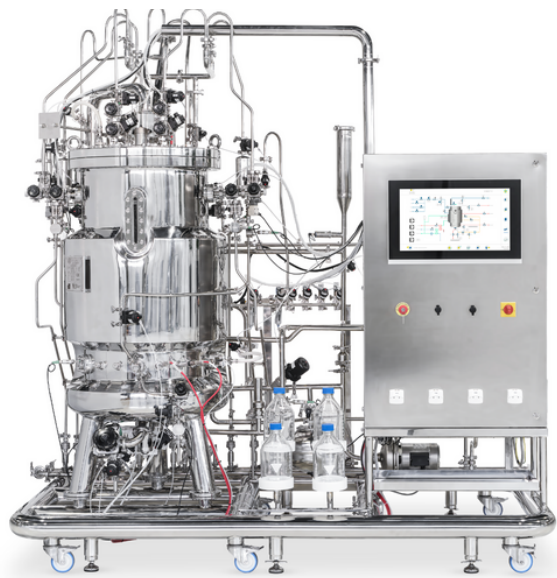

S-I SERIES

Fermenters/Bioreactors of the S-I SERIES are highly automated fermentation systems, available from 5 litres up to 30 m³, fully customized starting with the URS up to the final solution. All fermenters/bioreactors of this series are compact and flexible with the possibility to be installed even in places with limited space.



Pilot Scale Process
development



Scale up and scale-down
studies



Production



Standard industrial equipment

Fixed or wheeled skid options

Applications

THOUGHT



**BASIC
ENGINEERING**



**FEASIBILITY
STUDY**



MANUFACTURING

DELIVERY



**PERSONEL
TRAINING**



INSTALLATION

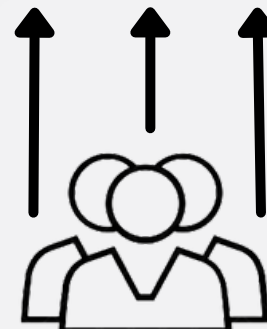

VALIDATION



APPLIED TO DIFFERENT INDUSTRIES



Biotech

Molecular biology , Biochemistry , Cell biology, Embryology , Genetics, Microbiology.



Pharma

Antibiotics, Antitumorals, Human Vaccines, APIs, Hormones, Non-addictive Pain Killers, Monoclonal Antibodies.



Food & Beverage

Meat/cheese/wine starters, Meat Preservatives, Cellular Agriculture, Flavors, Plant-based substitutes for meat products, Low Carb Drinks, Fermented Drinks.



Nutraceutical

Dietary supplements, Food additives.



Cosmeceutical

Bioactive ingredients, Hyaluronic Acid, Q10 Coenzyme.



Biomaterials

Biopolymers, Bioplastics.



Chemical & Petrochemical

Additives, Reagents, Refined commodities, Olefins.



Bioremediation

All microorganisms (bacteria, fungi, yeasts, algae) with the ability to modify toxic species.



Agriculture

Biofertilizers, Biopesticides, Algae Fertilizer.



Animal health & Nutrition

Veterinary vaccines, Animal feeding and supplements.



Probiotics

Lactobacillus, Bifidobacterium, Lactic acid bacteria.



Biofuels

Biodiesel, Bioethanol.

TRASFERRING LINES

Pipelines between units will be manufactured by our certified welders by means of orbital welding machines. Each welding will be certified, cleaned, mapped and passivated. Automatic valves, temperature and pressure sensors, steam traps, and all TC fittings and tubes will be part of our proposal.

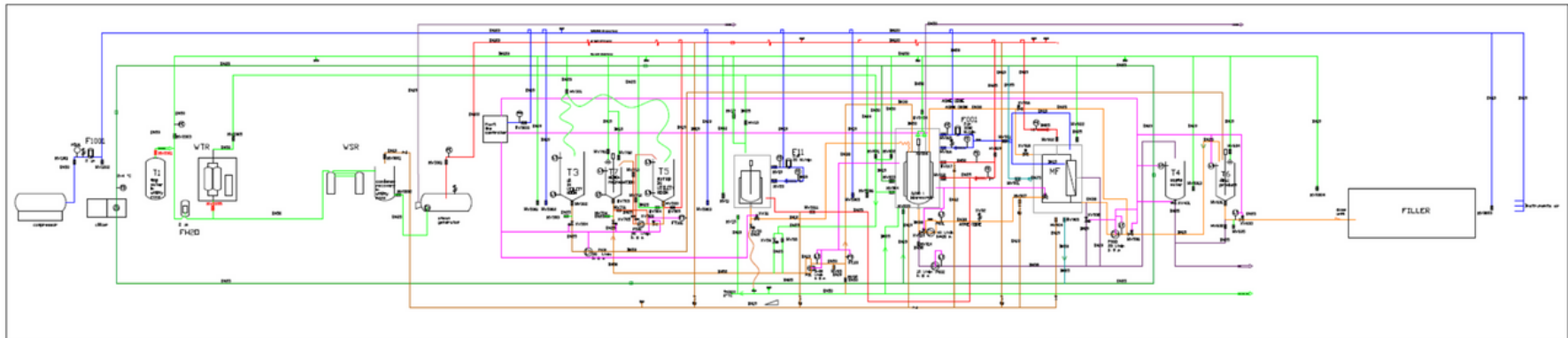
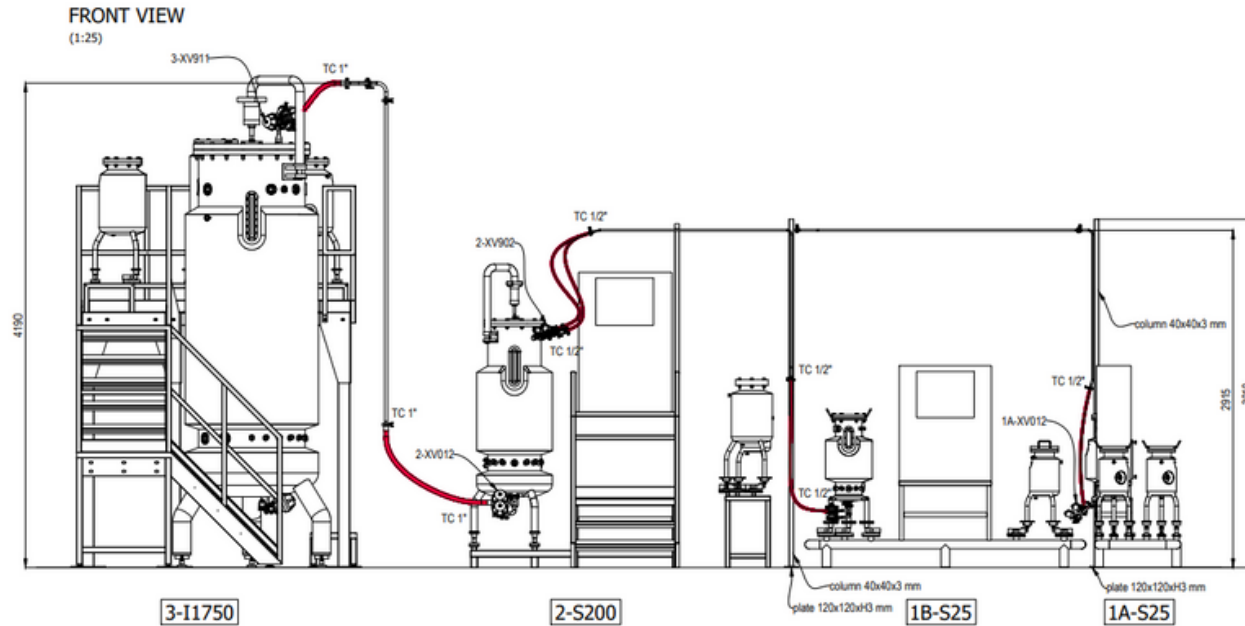

TURNKEY SOLUTIONS

Hardware Design

- to predict and control the risks
- easy to use, cost-effective, and durable
- P&ID, layout, configuration for components, drawings from 3D to 2D of the tank and all component

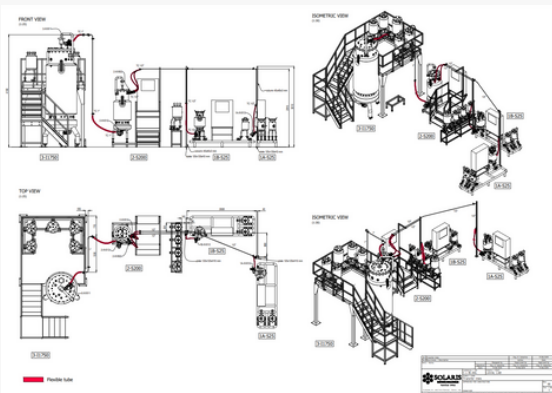

Software Design

- Automatic recording of process, online detection and real-time feedback on key parameters, CIP/SIP operations, remote centralized data collection and process monitoring
- flexibility, user-friendliness, easy scalability, stability, quick data exchange, reliability
- Integrated system architecture

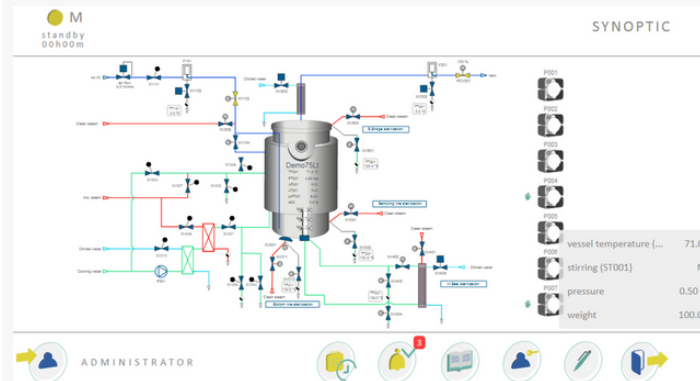

Handover

- Commissioning
- Qualification / Validation
- Start-up & training

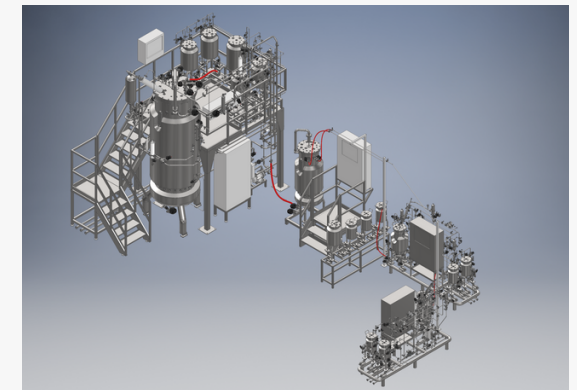

Leonardo

- Innovative SCADA software LEONARDO: a smart and user-friendly controller designed to provide a high level of automated management of the fermentation/cultivation processes
- Full version included in the equipment supply
- Data extraction in .csv format
- Remote access via PC, tablet or smartphone, with QR code scanning or dedicated portal
- Remote control
- Supervisory software for the management for the transfer lines

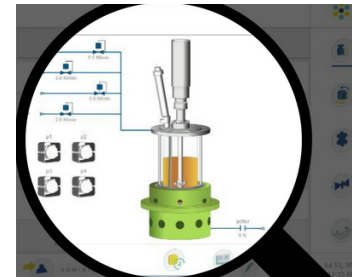

Synoptic

- real time 3D view
- parallel control
- manual control

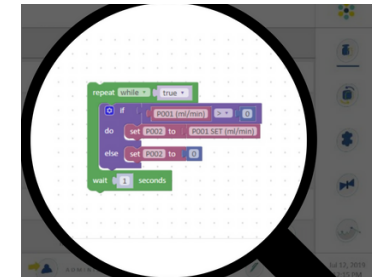

Logic Parser

- customized logic functions
- parallel logic blocks and functions

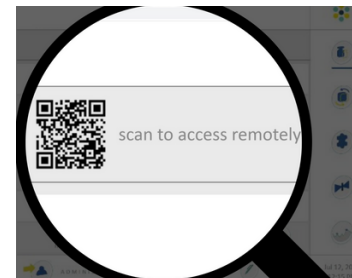

Remote Control

- unlimited number of profiles editor
- unlimited number of devices to be associated

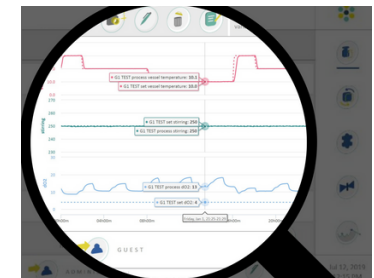

Trends

- custom acquisition time
- up to 6 values simultaneously display
- automatic graph comparison

PLANT VIEW

SYNOPTIC

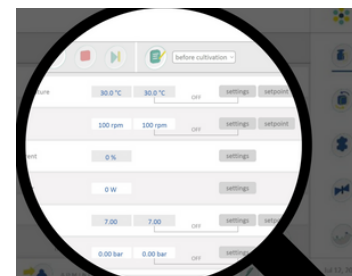
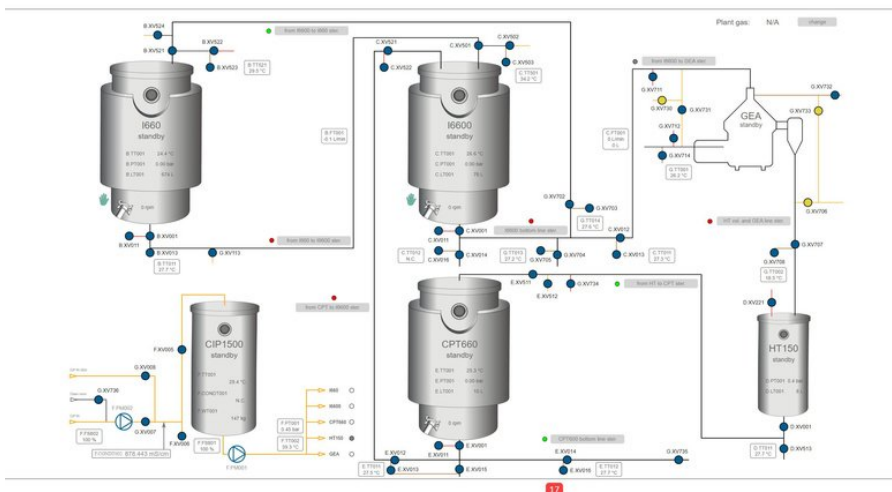

Workflow

- custom phase manager
- parallel visualization
- cascade settings
- peristaltic pumps function assignable from software

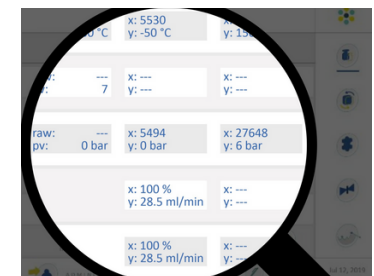

Calibration

- up to three-point calibration
- simultaneous calibration values for parallel work